

3-JAW CONCENTRIC GRIPPERS

INSTALLATION SIZE GED5006

▶ PRODUCT SPECIFICATIONS



▶ Gripping force diagram

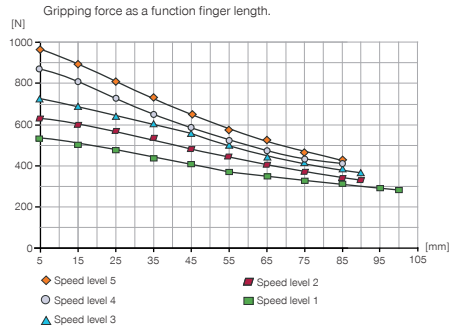

▶ Forces and moments

Displays static forces and moments that can also have an effect, besides the gripping force.

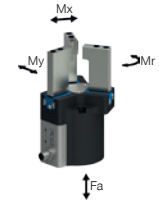

Mr [Nm]	43
Mx [Nm]	70
My [Nm]	46
Fa [N]	1250

▶ TECHNICAL DATA - BASIC VERSION

Order no.	GED5006N
Stroke per jaw [mm]	6
Control time [s]	0.035
Weight per jaw max. [kg]	0.4
Length of the gripper fingers max. [mm]*	100
Repetition accuracy +/- [mm]	0.01
Voltage [V]	24
Current consumption max. [A]	5
Operating temperature min. [°C]	5
Operating temperature max. [°C]	50
Protection to IEC 60529	IP64
Weight [kg]	1.09

*Depending on speed level selected

▶ TECHNICAL DATA - MODES

Order no.	GED5006N
Gripping force → ← min. / max. [N]	540 / 960
Gripping force ↔ min. / max. [N]	540 / 960
Travel time → ← min. / max. [s]	0,15 / 0,22
Travel time ↔ min. / max. [s]	0,15 / 0,22

Order no.	GED5006N
Gripping force → ← min. / max. [N]	540 / 960
Gripping force ↔ min. / max. [N]	-
Travel time → ← min. / max. [s]	0,15 / 0,22
Travel time ↔ min. / max. [s]	0,13

Order no.	GED5006N
Gripping force → ← min. / max. [N]	-
Gripping force ↔ min. / max. [N]	540 / 960
Travel time → ← min. / max. [s]	0,13
Travel time ↔ min. / max. [s]	0,15 / 0,22

TECHNICAL DRAWINGS

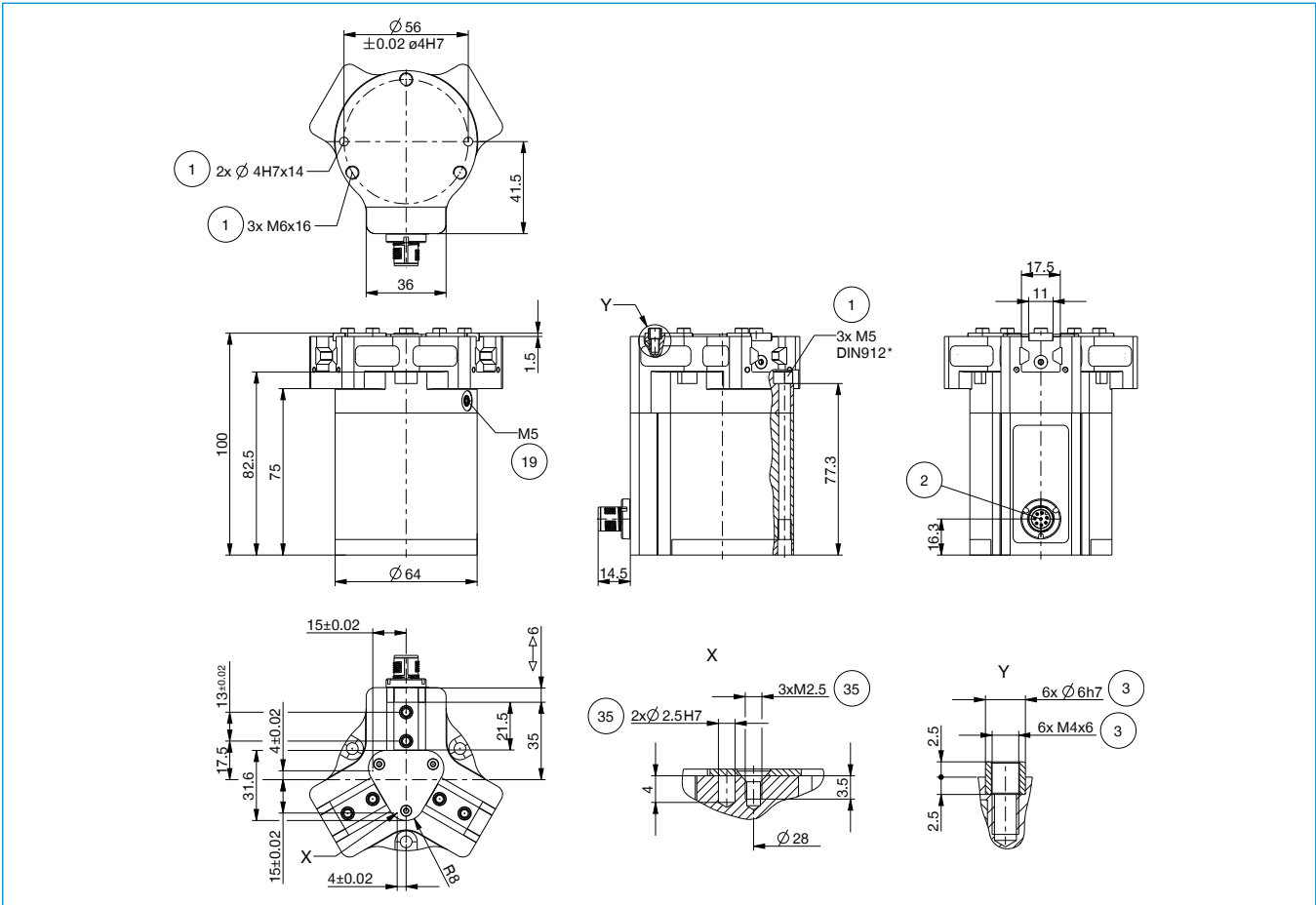

① Gripper attachment

② Energy supply

③ Fixing for gripper finger

⑱ Air purge connection option

⑳ Attachment option for customer-specific fittings

3-JAW CONCENTRIC GRIPPERS

INSTALLATION SIZE GED5006

1

Installation size GED5006 / 3-Jaw Concentric Grippers / electric / Grippers

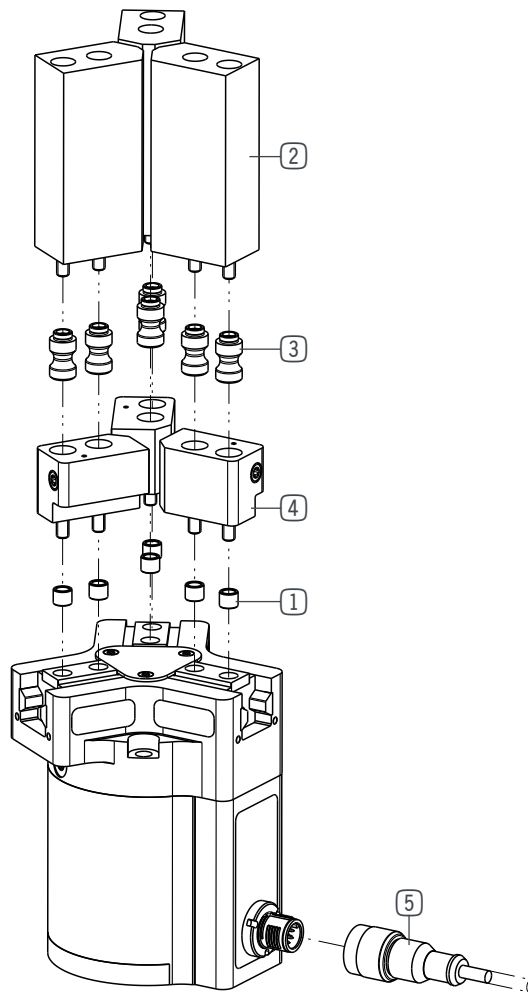

▶ INCLUDED IN DELIVERY



Centering Disc

024230

► RECOMMENDED ACCESSORIES



Universal jaw aluminium

UB5006AL



Universal jaw steel

UB5006ST



Pressure piece

ADS5006-05



Changeable jaw, loose-part-set

WB5006L



Changeable jaw, fix-part

WB5006F



Plug-in Connector Angled Cable 10 m - Female M12

KAW1000B8



Plug-in Connector Straight Cable 10 m - Female M12

KAG1000B8

► TECHNICAL DRAWINGS ACCESSORIES

One universal jaw is required for each gripper jaw **2**
A-A

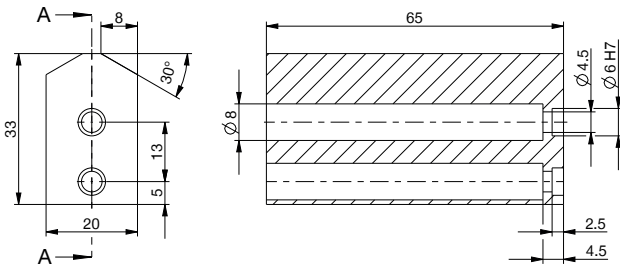

For each gripper jaw, one interchangeable jaw loose part set **3** and one interchangeable jaw fixed part **4** are needed

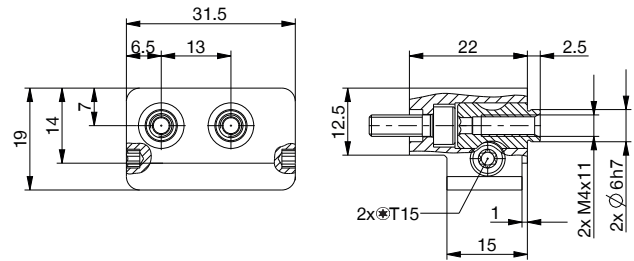

Gripper is fastened via the [pressure piece](#)

